

## Naizmenični raspored sa međuperforacijom

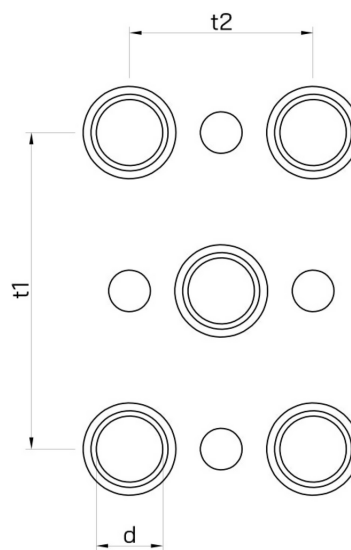
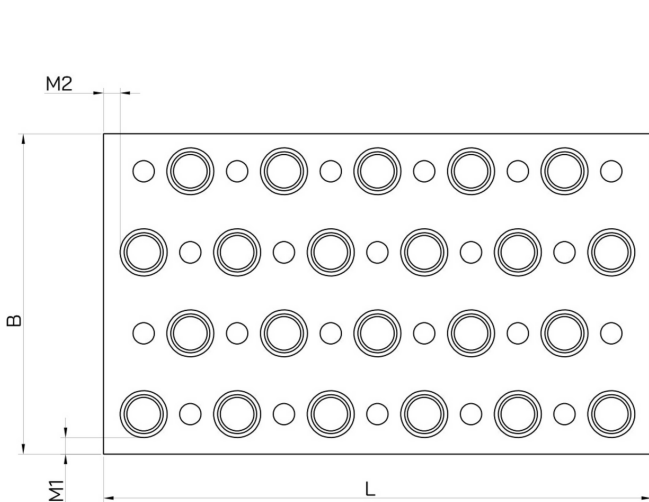

B - širina materijala  
L - dužina materijala  
t1, t2 - korak perforacije  
d - prečnik otvora  
M1, M2 - margina  
Fo - propusna moć (%)

$$Fo = \frac{d \times d \times 90,7}{t \times t} = (\%)$$

## Naizmenična perforacija

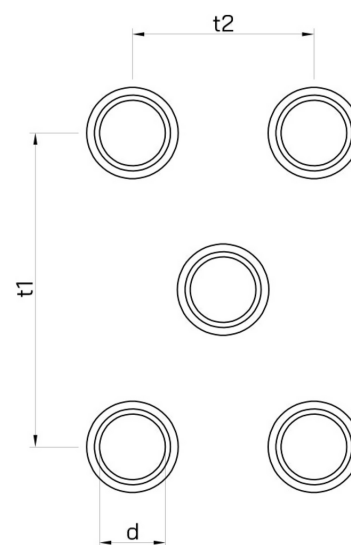
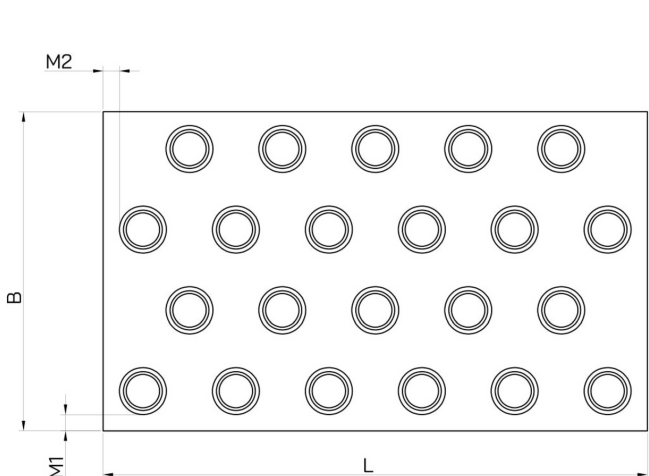

B - širina materijala  
L - dužina materijala  
t1, t2 - korak perforacije  
d - prečnik otvora  
M1, M2 - margina  
Fo - propusna moć (%)

$$Fo = \frac{d \times d \times 90,7}{t \times t} = (\%)$$